

## FLAT TOP PERFUME ATOMIZER

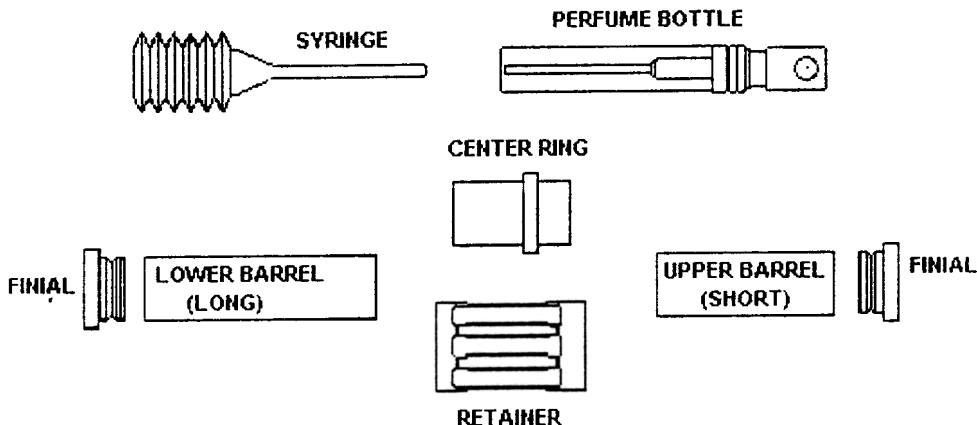

### TOOLING

A MANDREL

19/32 IN.

12A BUSHING

1 IN. X 1 IN. X 4 IN. WOOD

### TURNING WOOD

- 1- CUT WOOD 1/8 INCH LONG THEN BRASS TUBE.
- 2- DRILL WITH 19/32 DRILL AND EPOXY IN TUBE, YOU CAN SQUARE OFF YOUR TUBE BEFORE OR AFTER TURNING.
- 3- SAND & POLISH.

### ASSEMBLY

#### UPPER BARREL-SHORT TUBE

1. UPPER BARREL (CAP) PRESS ONE FINIAL INTO ONE END OF TUBE.

#### LOWER BARREL-LONG TUBE

1. PRESS IN OTHER FINIAL INTO DESIRED END (SO YOU CAN MATCH GRAIN)
2. SLIDE RETAINER INTO THE LOWER BARREL.
3. PRESS IN SHORT END OF CENTER RING, INSERT PERFUME BOTTLE, SLIDE ON CAP.
3. USE SMALL SYRINGE TO FILL PERFUME BOTTLE.

03/02